

## THE CHINA-BRAZIL EARTH RESOURCES SATELLITE (CBERS) PROGRAM

C.C. Ghizoni\*, Chen Yiyuan\*\* - General Program Managers

\*Instituto de Pesquisas Espaciais, São José dos Campos, SP, Brazil

\*\* Chinese Academy of Space Technology, Beijing, China

TC1

### ABSTRACT:

The cooperation between Brazil and China (PRC) in the space technology is the first program in a high technology area between developing countries. It attempts to develop space technology in both countries on a mutual benefit basis with each country being entirely responsible for its own share in the program.

In this paper we present the main characteristics of the spacecrafts being developed with special emphasis on its unique multi-sensor payload capabilities. The spacecraft carries three different imaging sensors on-board which possibilitates some new features to this class of satellites. The technologies used in designing the sensors are presented and discussed as well as the performance characteristics of the imagers. A ground segment compatible with the envisaged applications and users needs will be designed and implemented in the future.

KEY WORDS: Satellites, Imaging Sensors, Remote Sensing.

### 1. INTRODUCTION

The general objective of the program is the development and operation in orbit of two complex spacecrafts for observation of the Earth resources. The experience to be gained in conceptualizing and implementing a space segment with necessary ground base data reception, processing and interpretation system, and integrating the satellite based remote-sensing data with conventional data systems for resource management, will pave the way for taking up a program for operationalizing the remote sensing for both countries.

There are five parts for the CBERS overall system: (a) satellites; (b) tracking telemetry and command stations; (c) remote sensing data receiving and handling system; (d) launching vehicles and (e) launching site. The satellites will be launched by Chinese launch vehicles of the CZ-series, the CZ-4, a three-stage liquid propellant launch vehicle. CZ-4 was developed on the basis of CZ-3, with a designed system reliability greater than 0.85. It is specially designed for sun-synchronous orbit missions, with a capability of launching 2000kg in a 750km orbit. The remote sensing data will be received and handled separately by Chinese and Brazilian ground data receiving stations and processing centers. The TT&C ground stations in China and Brazil will complete the operation and management of the spacecraft in orbit under an unified program. The multi-sensor payload is composed of three imagers, a Data Collection System (DCS) for environmental monitoring, a space environment monitor for detecting high energy radiation in space and an experimental High Density Tape Recorder (HDTR) to record imagery on-board.

The unique characteristics of the CBERS Program which differs from the existing earth resources satellites is its multi-sensor imaging payload with different spatial resolutions. The three

imaging sensors aboard are the Wide-Field Imager (WFI), the High Resolution CCD Camera (CCD) and the Infrared Multispectral Scanner (MSS). The WFI has a wide swath width which gives a synoptic view with low spatial resolution. On the other hand, the CCD and the MSS sensors provide detailed information of a sampled area inside the WFI scene. In addition the CCD has an off-axis pointing capability and thus, any phenomenon detected by WFI may be "zoomed" by the oblique view of the CCD with a minimum time lag of three days. These multi-sensor data are specially interesting for ecosystem monitoring where high frequency information are required.

Mission Evaluation, Data Promotion and Distribution to users are of fundamental importance to assure the success of the program and are subject of discussion in this paper.

### 2. SYSTEM PERFORMANCE CHARACTERISTICS

CBERS will provide operational Remote Sensing and Data Collection services to users mainly of China and Brazil when operating with the configuration indicated in Figure 1. In addition it will be carrying on-board scientific and technological experiments with the aim of improving the design of future spacecrafts with similar characteristics. Such is the case of the Space Environmental Monitor (SEM) and the High Density Tape Recorder (HDTR).

The satellite will fly in a nominally circular sun-synchronous orbit with an inclination of 98.5 degrees with respect to the Earth's equatorial plane at an altitude of 778km. The mean local time at descending node is 10:30 AM and with a repeat coverage cycle of 26 days with 3 days as the interim period of the adjacent ground tracks.

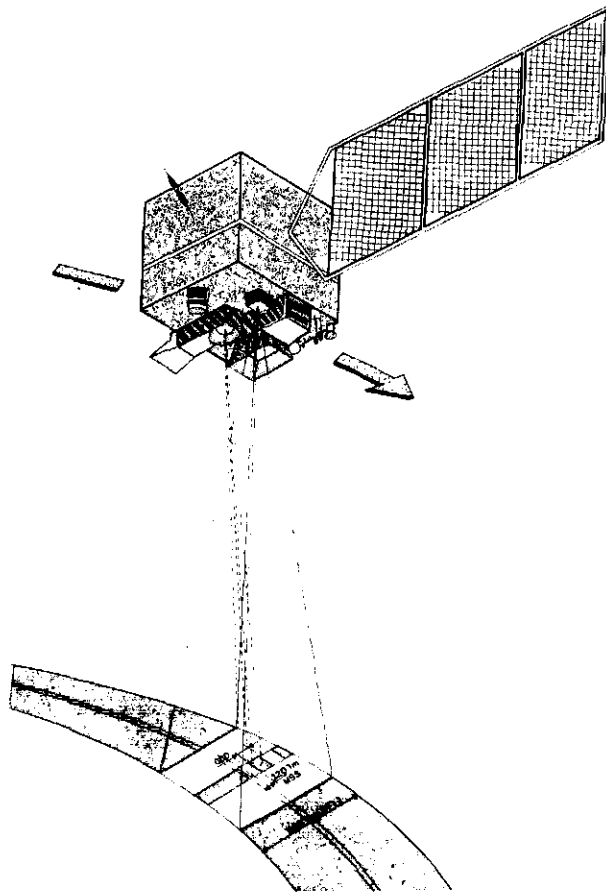

Mass: 1400Kg  
 Power: 1100 Watts  
 Dimension: 2.0x8.3x3.3m  
 Mean Altitude: 778km  
 Inclination: 98.504 degrees  
 Mean local solar time at  
 descending node: 10h30min  
 Revisit period: 26 days

Figure 1: CBERS Orbital Configuration

The High Resolution CCD Camera (CCD) has the function of acquiring high quality remote sensing image information of the earth's surface in five visible and near infrared spectral bands with a spatial resolution of 19.5 meters. The camera has a side-looking feature to decrease the interval between consecutive observations down to three days for any particular area, and reduce the influence of clouds obstruction. This side looking feature will also provide the camera with the capability of stereophotogrammetry. The Infrared Multispectral Scanner (IR-MSS) has the function of acquiring medium resolution infrared image (78 meters) information of the earth's surface in four spectral bands. The wide Field Imager (WFI) has the function of acquiring low resolution visible (260 meters) image information in two spectral bands of a wide swath of the earth's surface. The data of these sensors are totally compatible in such a way that they can be used simultaneously in a complementary way. The data from imaging sensors are transmitted to the earth ground receiving stations in the X-band (8.025-8.400GHz) in three different channels (two for CCD and one for IR-MSS and WFI) by means of 20W TWT (CCD) and 8W solid state (MSS and WFI) transmitters. The total transmission rate is about 112 Mbits/s with QPSK (CCD and WFI) and BPSK (IR-MSS) modulation and  $10E-6$  bit error

rate. In next section an extensive discussion of these imagers will be made.

The function of the data collection system is to relay data on meteorology, hydrology and oceanography from earth data collection platforms (DCP) to the ground receiving station. Each DCP transmits short digital data bursts at a fixed rate in the UHF band with a fixed time interval between consecutive emissions of the same DCP.

The satellite is earth-pointed, three axis stabilized by means of the Attitude and Orbit Control System (AOCS) which has the main functions: to establish the precise satellite orbital parameters after orbit injection and make adjustments throughout the life of the mission; to acquire the reference and maintain it; to control the solar paddle's orientation and maintain it nearly at constant angle with the sun vector. The pointing accuracy for the three axis is less than 0.3 deg (3 sigma) and the on-board knowledge of angles is 0.15 (3 sigma). The drift (3 axis) is less than  $1E-3$  deg/s (3 sigma), while the jitter is  $1E-4$  (1 sigma).

The Tracking, Telemetry and Control (TT&C) and On-Board Data Handling (OBDH) subsystems have the functions: to provide the satellite

cking and orbit measurement aids; to collect and transmit the housekeeping telemetry meters; to receive the commands and data from ground station and to perform the commands board in real time or delayed. There are two independent subsystems; one operating in S-Band and other in VHF/UHF bands. The system is compatible with ESA standards.

function of the Power Supply subsystem is to supply the normal power for all working equipment and consists of solar array generator (G), Ni-Cd batteries and electrical power control unit. The output power 1100 watts (End-Life) is distributed to the subsystem by a common bus-line.

The main body shape of the satellite is cuboid 2.0x1.8x2.2 meters. The envelope dimensions at the launching conditions are 2.95m diameter, 1.6m height and 2.0x8.15x3.26m in flight conditions. There is a single solar array wing in order to satisfy the requirement of the efficient cooler of the IR-MSS infrared detector. The supporting structure consists of a central cylinder, boarding and outside mounting plates made of Carbon Fiber Reinforced Plates (CFRP) and Aluminum alloy. Figure 1 shows the configuration of the spacecraft in orbit.

Thermal Control shall maintain the operating environmental temperatures using primarily passive control consisting of Multi-layer Insulators (MLI), thermal coating and heat pipes and secondarily using active control consisting of electrical heaters.

### 3. CHARACTERISTICS OF THE IMAGING SENSORS

The unique characteristics of the imaging sensors which makes CBERS different from the existing earth resources satellites is its multi-sensor imaging payload with different spatial resolutions. The three imaging sensors aboard are the Wide-Field Imager (WFI), the High Resolution CCD Camera (CCD) and the Infrared Multispectral Scanner (MSS). The data obtained from these sensors possibilitate that any combinations of images with different spatial resolutions and spectral bands can be used in the study of natural targets. A pictorial view of the area covered is shown in Figure 2.

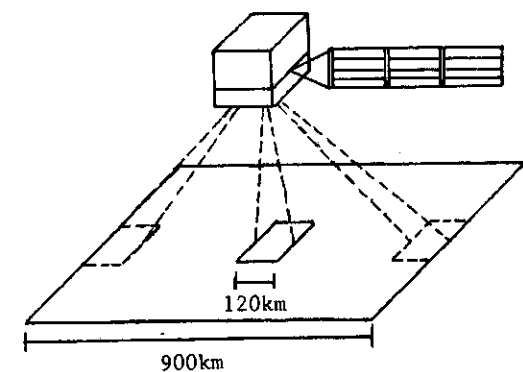

Figure 2: Sensors Covered Area

### 3.1 The CCD Camera

The high resolution CCD camera is the main imaging sensor of CBERS. It consists of optical, detection, and calibration systems, and electronics block, viewing mechanism, the structure and a thermal control system as shown in Figure 3. The relevant characteristics are:

Number of bands: 5

Spectral Bands: B1: 0.45 to 0.52 micrometers  
 B2: 0.52 to 0.59 micrometers  
 B3: 0.63 to 0.69 micrometers  
 B4: 0.77 to 0.89 micrometers  
 Panchromatic: B5: 0.51 to 0.73 micrometers

Noise equivalent reflectance: 0.5% for 60 deg. solar incidence angle

Focal length: 520mm

Aperture: f/4

Field of View: 8.32 deg

Instantaneous Field of View: 25 microradians

Swath width: 113km

Pixels per band: 5812

Spatial resolution: 19.5m (nadir view)

Band to Band registration: Better than 0.3 pixel

Side-looking capability: from -32 to +32 deg in steps of 2 minutes of arc

Line sampling period: 2.898 milliseconds.

3.1.1 Optical and Detection System The optics of the CCD Camera is composed of a pointing mirror, a single telescope, focussing mechanism, a prism for spectral separation and a calibration assembly. The telescope used an all refracting lens system with a focal length of 520mm and relative aperture of f/4. This design allows reaching diffraction limited image of a linear string on the focal plane of the system both for multispectral and panchromatic bands.

The focal plane assembly is composed of the spectral beam splitter, the butting prisms, CCD arrays and focal drive mechanism. The optical path is shown in Figure 3. The spectral beam splitter consists of dichroic prisms and it is used to separate the incoming light beam into four discrete bands by means of filters and beam-splitting coating. The distance between lines of the panchromatic and multispectral bands is 20mm. To form a linear image of approximately 6000 pixels, three CCD arrays of 2048 elements each (Fairchild CCD 143A) are combined by means of butting prisms to form a long array. The detector elements near the boundaries of the central CCD array are not uniformly illuminated causing a "shading" on these pixels. For the case, about 154 pixels at

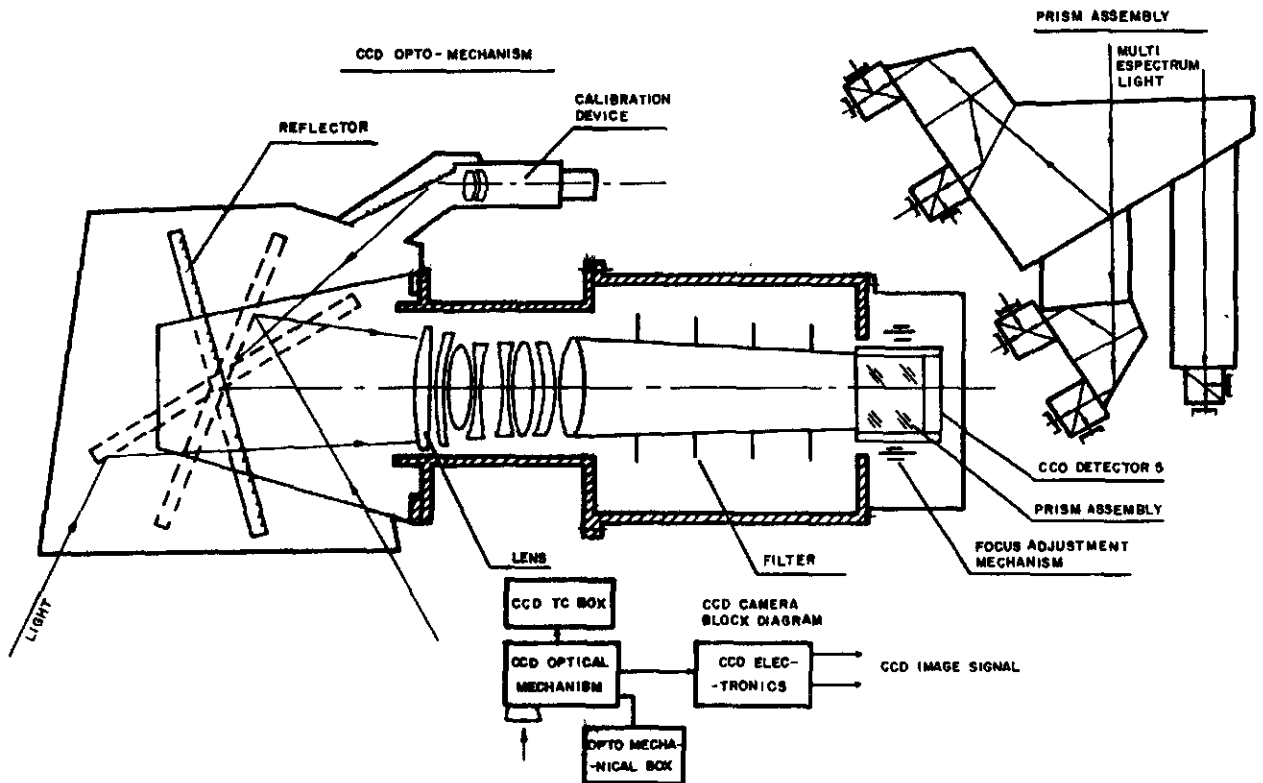

Figure 3: High Resolution CCD Camera

each end of the central array are affected by the "shading". To deal with this phenomenon an overlap of the CCD arrays is necessary so that the effective number of pixels per band turns out to be 5812.

In order to assure the image quality requirements in a two years lifetime, and to overcome intactly the hostile environment during the launching phase, the focal plane assembly is adjustable along the optical axis direction controlled by telecommand from ground if the image quality undergoes degradation. The mechanism is driven by a motor through a precise screw mechanism. The adjustable range is +/- 2mm in steps of 3 micrometers.

**3.1.2 Electronics** The electronics is consisted of a CCD driver unit, a video amplifier, a sequential signal generator, a combining and processing unit, gain control circuits and command electronics for the drive mechanism. The signals generated by the CCD arrays are handled by the video signal processing circuits which distribute the five bands into two transmitting channels each one containing three bands with band 3 (B3) included in both channels. The PCM encoders execute the 8-bit A/D conversion on both channels, separately. In this process the image signal from band 3 (B3) is recombined in a such way that it is transmitted into two channels. The non-uniformities between the two channels can be then corrected by processing on ground.

The gain of the amplifier chain is adjustable in order to take full advantage of the dynamic range of the A/D converter. The nominal values

for the gain of each amplifier are: 0.25; 0.5; 1; 2.

**3.1.3 Radiometric Characteristics** The choice of the spectral bands took into account the main mission objectives and the atmospheric windows. The spectral bands are conventional ones as those of Landsat TM while a panchromatic band (0.51 to 0.73 micrometers) was added for cartographic purposes. The filters that define the spectral bands, designed to minimize the interference between bands, have an out-of-band transmission of less than 1%.

The characteristics of the raw image generated by the high resolution CCD camera are as follows:

Relative accuracy along lines: +/- 10%

Relative accuracy in one band: lower than 5%

Calibration: in-band radiometric precision of 3%

Linearity: 1% over the entire dynamic range

Inter-band and absolute calibration accuracy: 3% for each combination of two spectral bands and an absolute calibration of 10%

Modulation Transfer Function: Along track: 0.21  
Cross track: 0.32

In order to equalize CCD response and to correct for any changes in response that may occur (aging of optical coatings, contamination of optical surfaces, degradation of CCD detectors, etc.), the CCD camera is equipped with a calibration system controlled through telecommands from ground. A tungsten filament lamp of known spatial profile provides a means of illuminating the CCD arrays. The lamp uniformity required, across the field, is better than 5%. This system is used to determine two coefficients for each of the 5 x 6144 elements, namely to correct for individual dark current and electronic offset and for individual gain variations.

The absolute calibration is made by using a radiometric test site, where ground measurements of reflectances and of atmospheric parameters will be combined with mathematical models to determine scene radiance at the spacecraft position.

### 3.2 The Infrared Multispectral Scanner

The IR-MSS is other important sensor of CBERS which provides complementary information in the infrared portion of the spectrum to the CCD camera imagery data. It consists of a mainframe, an electronic unit, an on-board calibration assembly, a radiative cooler and a thermal control unit. The mainframe consists of a scan mirror, primary optics (telescope) prime focal plane assembly, relay optics, a scan line corrector and a scanning angle monitor, a set of detectors and associated preamplifiers. This is shown schematically in Figure 4. The most relevant characteristics of the IR-MSS are:

Number of bands: 4

Spectral Bands: B6: 0.50 to 1.10 micrometers  
 B7: 1.55 to 1.75 micrometers  
 B8: 2.08 to 2.35 micrometers  
 B9: 10.4 to 12.5 micrometers

Noise equivalent reflectance: 0.4% (B6); 1.0% (B7); 2.0% (B8)

Noise equivalent temperature: 1.2 deg K (B9)

Focal length: 1000mm for bands B6, B7, B8  
 500mm for band B9

Aperture diameter: 250mm

Field of view (FOV): 8.78 deg

Instantaneous field of view (IFOV): 0.1 milliradians (B6, B7, B8)  
 0.2 milliradians (B9)

Swath width: 119.5km

Spatial resolution: 77.8m (B6 to B8)  
 156m (B9)

Registration:

- within prime focal plane (PFP): less than 0.3 IFOV
- within cooled focal plane (CFP): less than 0.3 IFOV
- CFP to PFP: less than 0.6 IFOV

Modulation Transfer Function (MTF): better than 0.4

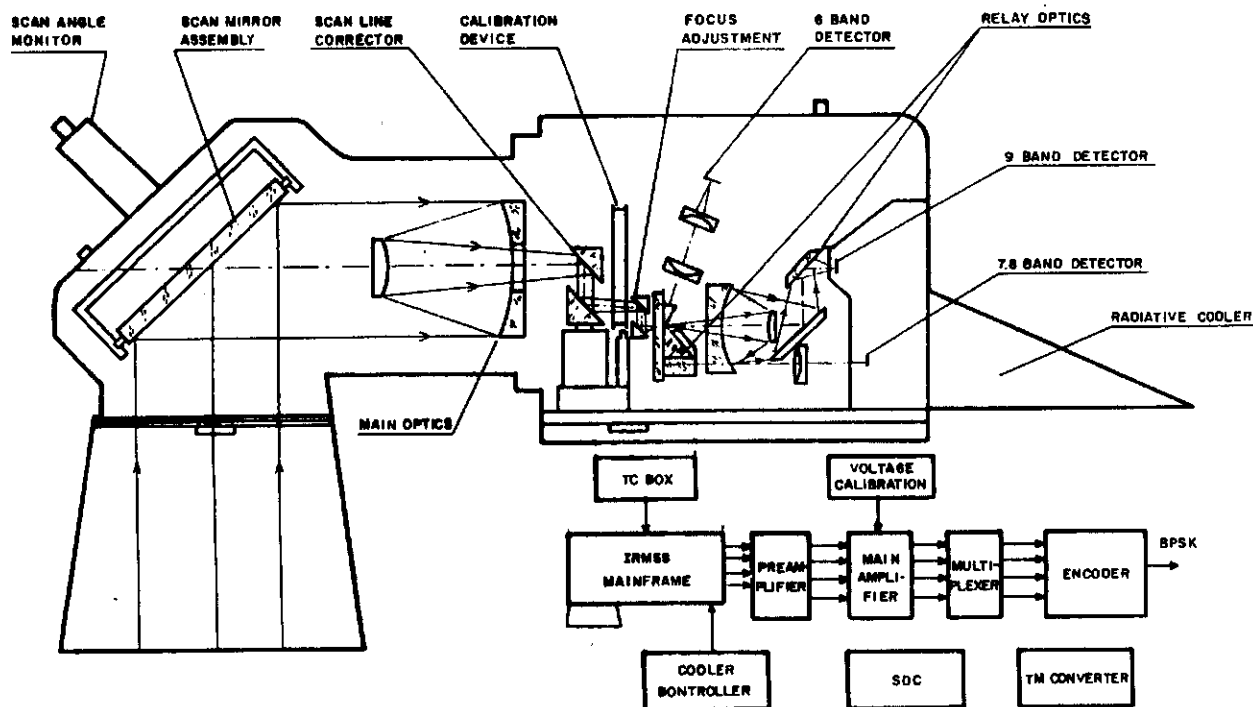

Figure 4: IR Multispectral Scanner

3.2.1 Optics and Detection System The optics of the IR-MSS is composed of a prime and relay optics assemblies, and scanning mechanism. The prime optics assembly consists of a Ritchey-Chretien telescope system of double-mirrors. The relay optics is used to separate the spectral bands, and at the same time to focus the incident radiation into the detector arrays.

The effective focal plane is actually a combination of two focal planes coupled optically so that they appear as one. The prime focal plane is the uncooled plane where the detectors for Band 6 are installed while the detectors for Bands 7 to 9 are in a cooled focal plane refrigerated by a radiative cooler. The relay optics is used to make the cooled plane appears optically in the same focal plane as the prime focal plane.

The linear swinging scan-mirror consists of the scan-mirror assembly, scan-line corrector assembly and scan-angle monitor assembly. The scan-angle monitor assembly has the scanning function in the cross-track direction. The scan-line corrector has the function of correcting effects due to the spacecraft orbital motion during the active scan periods. The scan-line corrector is a motor-driven, two-mirror system that rotates at a rate equal to and opposite to the angular velocity of the spacecraft in the forward track direction. The scan-angle monitor is used to measure accurately the relative position and direction of the scan mirror.

The detection system is composed of a set of detector arrays and of the associated electronics. The basic characteristics of the detectors are as follows:

Band 6: Type: PIN silicon photodiode  
 Number of elements: 8 (+8 backup)  
 Element size: 0.10\*0.10mm<sup>2</sup>  
 Responsivity (Average): 0.40 A/W  
 Dark current: less than 1\*E-11 A

Bands 7,8: Type: HgCdTe  
 Number of elements: 8 (+8 backup)/band  
 Element size: 0.10\*0.10mm<sup>2</sup>  
 Detectivity: better than 2\*E11cm  
 (Hz)<sup>1/2</sup>/W (165K)

Band 9: Type HgCdTe  
 Number of elements: 4 (+4 backup)  
 Element size: 0.10\*0.10mm<sup>2</sup>  
 Detectivity: better than 1\*E10cm  
 (Hz)<sup>1/2</sup>/W (105K)

The radiative cooler has two stages with temperatures of 165K +/- 1K and 105K +/- 0.5K.

3.2.2 Electronics The electronics block has the following functions:

- perform analog to digital conversion of image information;

- transmit time sequence control pulse to the multiplexer for each band and make parallel to serial conversion;
- from starting signal form the swing-scanning device to coordinate the operation among the scanner units;
- produce standard clock;
- produce clamp pulses to main amplifiers;
- receive auxiliary data and command for OBDH subsystem;
- format the image data, calibration data, auxiliary data and some telemetering parameters into a serial data stream in the specified data format;
- transmit formatted data to IR-MSS data transmission subsystem.

3.2.3 Radiometric characteristics The choice of the spectral bands (7-9) was based on previous experience acquired with Landsat system. Band 6 was added to provide visible reference imagery in the interpretation of infrared images and radiometric correction information of the atmospheric path and of Earth's albedo.

The characteristics of the raw image generated by the Infrared Multispectral Scanner are as follows:

Band-to-band radiometric precision: better than 3%

Channel-to-channel radiometric precision: better than 2%

Absolute calibration accuracy: within 10%

Modulation Transfer Function: better than 0.4

Scan rate: 5.3908Hz +/- 0.03%

Overlap: less than 0.2 IFOV

Scan line length: 74200 microseconds

Scan line error: less than 9.66 microseconds over 100 scans

Number of pixels/scan: 1536 band 6-8  
 768 band 9

Scan profile nonlinearity: less than 1 IFOV (peak)

Scan profile repeatability: less than 0.2 IFOV (rms) over 100 scans

The calibration assembly consists of sun calibration, internal lamp calibration, blackbody calibration and voltage calibration. The standard voltage calibration is used to correct nonlinearities of the primary amplifier, while the lamp calibration has three tungsten filaments at constant current and it

is used to correct relay optics, detectors and amplifiers for bands 6 to 8. A standard high temperature blackbody is used to correct the relay optics, detectors and amplifier for band 9. The low-temperature standard is provided by the first stage (165 deg K) of the radiative cooler. Sun calibration will be used to correct prime optics, relay-optics and the electronic unit of the scanner. All the calibration data will be transmitted to the ground image stations.

### 3.3 The Wide Field Imager (WFI)

The WFI sensor is a complementary sensor to the high resolution CCD camera of CBERS. It consists of an electro-optics module, signal processor and a modulator. The electro-optics module houses the collecting optics objective lenses, spectral filters, the CCD detectors with their driving electronics and the radiometric calibration device. The signal processor controls the CCD operation, interfaces with the on-board data handling subsystem to gather relevant spacecraft data, accepts the telecommands, generates telemetry signals on the imager status and provides the video signal that will be fed into the modulator. The modulator is composed of a QPSK modulator and a combinator. The relevant characteristics of the WFI sensor are:

- Number of bands: 2
- Spectral bands: B10: 0.63 to 0.69 micrometers  
B11: 0.77 to 0.89 micrometers
- Noise equivalent reflectance: better than 1%
- Focal length: 39.50mm
- Field of View (FOV): 60 degrees
- Instantaneous Field of View (IFOV): 1.13 min
- Fnumber: F/4
- Total number of pixels per image line: 3456  
(1728 x 2)
- Swath width: 885km
- Spatial resolution: 256m
- Band-to-band registration: better than 0.3 pixel
- Quantization: 8 bits
- Modulation Transfer Function (MTF): better than 0.60

**3.3.1 Optics and Detection System** The optics of the WFI is an all refractive lens system composed of four objectives assembly. For each spectral band there are two objectives each of them with a FOV of 30 degrees, pointed to the Earth's surface in a way to reproduce a swath width of a single objective of 60 deg FOV. The lens system arrangement is depicted in Figure 5. The electronics for WFI is a

simplified version of that one used for the CCD high resolution camera. Its main functions are:

- Timing logic
- CCD driving
- Data formatting
- OBDH interfacing
- Video signal processing
- Multiplex of the video channels
- Analog to digital (A/D) conversion

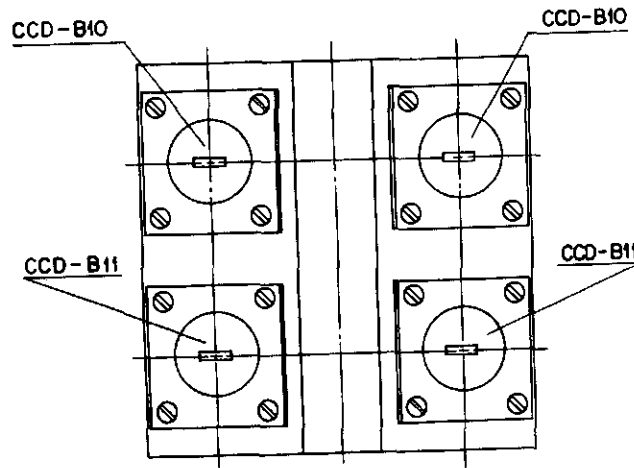
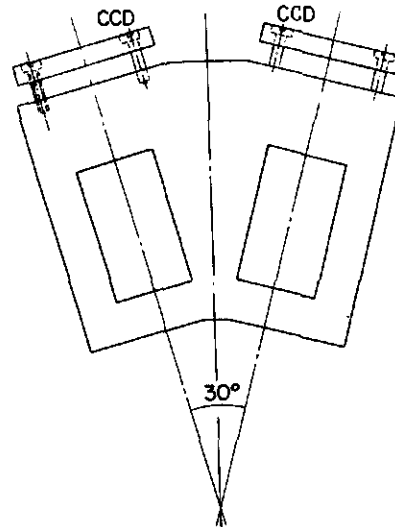

Figure 5: WFI Lens Arrangement

The design is optimized for minimum power consumption, mass and volume. The spectral band selection is oriented to optimize vegetation monitoring and biomass surveys. The bands are the same as bands B3 and B4 of CBERS CCD high resolution camera.

### 3.4 Standard Products

Scenes produced by the processing stations will meet the following standard correction levels:

#### a. Level 0 products

These are "raw" images with no correction applied and are distributed on CCT's only.

#### b. Level 1 products

These are system-corrected images. Level 1 is subdivided in two sub-levels: sub-level 1A when only the radiometry of the pixels are corrected; sensors equalization (stripping effect removal), sun angle correction, Modulation Transfer Function (MTF) correction. Sub-level 1B when both geometric and radiometric corrections are applied. The geometric corrections are applied to compensate for Earth rotation and curvature; panoramic effects, satellite attitude, position and velocity.

In addition level 1B scenes may be corrected to fit any standard map projection. They are distributed either on CCT, film or paper prints.

#### c. Level 2 products

These are geocoded scenes composed of mosaiced North-oriented scenes. Level 2 is also subdivided in 2 sub-levels: sub-level 2A where geometric corrections have been refined by using Ground Control Points (GCP's) in order to meet the standard precisions; the terrain relief is not considered for these corrections. Sub-level 2B is the same as level 2A with the addition of corrections to compensate for terrain relief by using Digital Terrain Model (DTM).

**3.4.1 Product Precisions** The radiometric precision is better than 2DN for all bands. The location accuracy of level 1B scenes is better than 2km with an internal distortion RMS error not exceeding 3 pixels, while level 2A scenes have a location accuracy equal or better than 2 pixels and internal distortion RMS error better than 2 pixels (excluding errors due to terrain relief). Level 2B scenes must conform to cartographic standards. First generation film products have minimum density of 2.0D and exposure stability better than 2% at maximum exposure.

### 3.5 Image Telemetry

The CBERS Image telemetry is composed of the data from CCD camera, from IR-MSS and from WFI with a spectrum diagram as depicted in Figure

6. The data of bands B2, B3 and B4 are transmitted in channel 1 and of bands B1, B3 and B5 in channel 2 using TWT power amplifier operating in X-band. Each TWTA is connected with one antenna. Bands B6-B11 from IR-MSS and WFI are transmitted using Solid State Power Amplifiers. The total transmission rate is  $2 \times 53 + 6.13 + 1.1 = 113.23 \text{ Mbits/s}$ .

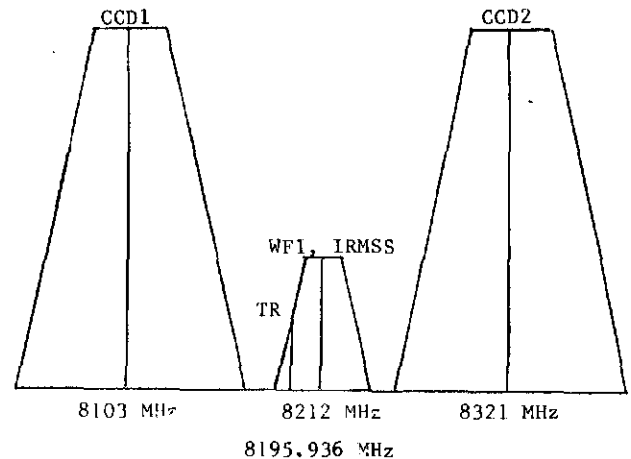

Figure 6: RF Spectrum

## 4. MISSION EVALUATION, DATA PROMOTION AND DISTRIBUTION

The bottlenecks for a wider acceptance of the remotely sensed data by the user community nowadays are the long delivery time and the relatively high price to buy satellite products. Thus, we are convinced that the success of the CBERS mission; from the users' points of view, relies on:

- an affordable product price for most users;
- the capacity to provide near real-time data for operational systems and delayed-time data for scientific studies;
- a system transforming the multisensor raw data into useful information that the user community has an easy and rapid access.

If these three aspects can be achieved, then, CBERS will contribute significantly to the application of remotely sensed data to resource managements. It is strongly recommended to concentrate efforts on developing efficient processing techniques and analysis methodologies to handle the multisensor data of CBERS, and consequently, low cost products can be provided in a short delivery time.

### 4.1 Requirement of Mission Evaluation

The objective of the mission evaluation is to verify whether the collected satellite data meet the pre-established geometric and radiometric specifications. Users can only apply the remotely sensed data appropriately once the data qualities are known. Therefore, the following items have to be answered:



to what extent the sensors performances meet their pre-established specifications?

to what extent the bulk products maintain the same qualities as the expected sensor performance?

to what extent the atmospheric factor influences the radiometric fidelity of the marginal pixels of the WFI and the off-nadir scenes of the CCD? and to what extent the atmospheric effects can be alleviated by the correction task?

to answer these questions, the mission valuation from the user's points of view can be divided into three groups:

Phase E Evaluation (Just after spacecraft being injected into orbit)

at this stage sensor performance and data quality (i.e. radiometric and geometric) should be evaluated to verify if they meet the pre-established specifications.

Periodical Evaluation

the system should be set up to verify periodically the radiometric accuracy of instruments during their lifetime in orbit and to correct for any changes in response that may occur.

Software to Guarantee the Image Quality

there are two types of software that have to be developed immediately to guarantee the image quality:

atmospheric correction software for the WFI and the off-nadir CCD scenes.

registration software for data from different sensors (ex. CCD and IR-MSS) or satellites (ex. Landsat and CBERS)

registration of political boundaries (i.e., state and country boundaries) on the WFI products

## 2 Requirements for Data Promotion

in order to promote the utilization of CBERS data, the user's community should be well informed about sensors characteristics, product formats and other possible applications of ERS data. To achieve these objectives the following data promotion steps should be implemented:

4.2.1 Pre-launch Campaign Using Simulated  
The CBERS data will be simulated using existing remote sensing satellite data. Main characteristics that can be simulated are spectral bands and spatial resolutions. Other features such as the image frame (swath), MTF etc. cannot be studied from this simulation package. The purpose of this pre-launch simulation campaign is to provide users an

opportunity to test the usefulness of CBERS data in many applications.

The preparatory stage of the pre-launch campaign is divided into two stages; they are the SMALL-SCALE SIMULATION and the LARGE-SCALE SIMULATION:

Small-scale simulation

Programs to simulate CBERS data will be developed and evaluated on a few small scenes of 512x512 pixels. After the evaluation an A.O. of the pre-launch campaign will be announced to the user community.

Products to be simulated are:

- a) for WFI
  - two images of the vegetation index
- b) for IR-MSS
  - one B and W image of the panchromatic band
- c) for CCD
  - one color composite of B1, B2 and B3
  - one color composite of B2, B3 and B4
- d) merged products
  - one color composite of B3 and B4 of CCD and B1 of the IR-MSS
  - one color composite of B3 and B4 of the CCD and the B2 of the IR-MSS.

Large-scale simulation

Programs to simulate CBERS data in large scale will be implemented in Cachoeira Paulista to produce simulated full or quadrant scenes according to the selected proposals of the A.O.. The quantity of the simulated products at this stage depends on the capacity of Cachoeira Paulista.

Emphases of the simulation studies should be given to data of the WFI and the pan. band of the IR-MSS. This is because that utilizations of spectral bands of the CCD and the IR-MSS have been familiarized by the user community through the experience acquired on LANDSAT and SPOT. Even though application of vegetation index for biomass monitoring have been demonstrated using AVHRR of NOAA or LANDSAT-TM; this is the first time an orbital sensor which will provide information about vegetation condition with a spatial resolution of 260m. On the other hand, besides for the calibration purpose, applications of the panchromatic band of the IR-MSS is not yet clear. Investigations by the users community at this stage is recommended. The reason to simulate the merged products is more to guide the future data processing group than to prepare the user community.

Results of selected proposals using simulated CBERS data will be presented in a symposium to be held in the 2nd semester of 1991.

4.2.2 Post-launch Data Evaluation After launch, a phase E evaluation of sensor performance and data quality will be executed. Once the data quality has been guaranteed, the mission will be announced as operational. At this moment, a post-launch data evaluation program providing cost-free CBERS data to users will be initiated. The announcement of opportunity for participating the post-launch data evaluation program can be officialized in the symposium of 1991 mentioned above. The post-launch data evaluation program should have a duration no longer than one year. Another symposium to present the study results of this post-launch campaign is scheduled in the first semester of 1994.

Demonstration projects using simulated or real CBERS data should be carry out. The criteria for selecting demonstration projects are:

- High priority issue
- Well-conceived plan for transferring this new technology
- Well-defined recipient community
- Positive impact of introducing CBERS data

Since the spectral bands of the CCD and the IR-MSS are the same as that of Landsat TM but with different spatial resolutions, little efforts will be required for users to get acquainted with these spectral data. Nevertheless how to use these multi-sensor data efficiently and how to transfer the data analysis and modelling system to the user community require attention of the CBERS Application Segment Group (ASG). The data analysis and modelling system is a new concept of the CBERS which differs from the present operational satellites. This system should have the capacity of extracting meaningful information from CBERS multisensor data and make it easily accessible to users. Thus, it is essential that maximum efforts are allocated to software, hardware and analysis model developments immediately to guarantee the success of the CBERS culture.